

PICK-UP SOLUTIONS

12 | 14 | 14 | 16
JIB | JIB

Tecnologia e sicurezza per lavorare in quota
Safety and technology for aerial works
Technologie et sécurité pour travaux aériens
Technologie und Sicherheit bei der Arbeit in der Höhe
Tecnología y seguridad por trabajos aéreos
Технология и безопасность для работы на высоте



PICK-UP SOLUTIONS

12 | 14 | 14 | 16
JIB | JIB



- Altezze di lavoro da 12 a 16 m
- Pantografo singolo o doppio e braccio telescopico per raggiungere un'altezza di scavalco fino a 6 m
- Articolazione finale JIB sui modelli New Eurosky
- **Comandi 100% idraulici**
- Presa elettrica 230 V in navicella
- Sistema di accensione e spegnimento del motore dalla navicella
- Contatore in cabina
- Possibilità di **cassone libero aperto o chiuso per carico materiali e utensili da lavoro sui modelli X4**



- Working height from 12 to 16 m
- Single or double pantograph and telescopic boom to obtain an **up and over height to 6 m**
- Articulated terminal boom JIB on New Eurosky models
- **100% hydraulic controls**
- Electric power tap 230 V in basket
- Engine start & stop from the basket
- Hour-counter in the cabin
- Possibility of **free body or closed box for transport of tools and other material on X4 models**



- Hauteur de travail de 12 à 16 m
- Pantographe simple ou double et bras télescopique pour atteindre une **hauteur de dépassement jusqu'à 6 m**
- Bras articulé terminal JIB sur les modèles New Eurosky
- **Commandes 100% hydrauliques**
- Prise électrique 230 V dans la nacelle
- Marche et arrêt du moteur du véhicule dans le panier
- Compteur d'heures dans la cabine
- Possibilité d'installer une **caisse fermée pour le transport d'outils et d'autres matériels sur les modèles X4**



- Arbeitshöhe von 12 bis 16 m
- Teleskopgelenkarm und einziger oder doppelter Pantograph um eine **Übergreifshöhe bis 6 m** zu erreichen
- Korbarm auf den Modellen New Eurosky
- **Vollhydraulische Steuerung**
- Stromanschluss 230 V im Hebekorb
- System zum Ein- und Ausschalten des Motors vom Hebekorb aus
- Stundenzähler im Führerhaus
- **Freier Kasten für Arbeitsmaterialien und Werkzeug für die X4 Modelle**



- Altura de trabajo de 12 a 16 m
- Brazo telescópico y pantógrafo simple o doble para obtener una **altura para superar obstáculos hasta 6 m**
- Articulación final JIB sobre los modelos de New Eurosky
- **Mandos 100% hidráulicos**
- Toma de corriente de 230 V en la cesta
- Arranque & Detención desde la cesta hasta el motor vía control remoto
- Contador de horas en la cabina
- **Cajón libre abierto o cerrado para la carga de materiales y herramientas de trabajo para modelos X4**



- Рабочая высота от 12 до 16 м
- Телескопический шарнирный рычаг и одинарный или двойной пантограф для достижения **высоты подъема до 6 м**
- Гусёк (Jib) для New Eurosky
- **100% гидравлическое управление**
- Наличие электрической розетки 230 В в люльке
- Система пуска и останова двигателя непосредственно из люльки
- Счётчик моточасов в кабине
- **Свободный открытый или закрытый ящик для транспортировки инструментов и других материалов для X4**



Bini Gru di Bini Roberto

Sede Legale Via Aldo Moro, 62 - 40050 Castello d'Argile (BO) - Italy
Sede Operativa: Via XX Settembre, 7/C - 40057 Cadriano (BO) - Italy
P.Iva 00023611205 - C.F. BNIRRT63T06E514U - REA 307372
Tel. +39 (0) 51 0827261 - Mob. +39 348 7614707
www.binigru.it info@binigru.it



↗ SALI CON NOI ↗ CLIMB WITH US ↗ MONTE AVEC NOUS ↗ STEIGEN SIE MIT UNS AUF ↗ SUBE CON NOSOTROS ↗ ПОДНИМАЙТЕСЬ С НАМИ

www.officinecomet.com

- FREE SPACE IN THE REAR BODY TO TRANSPORT MATERIALS
- SINGLE CAB VEHICLE
- FROM 2.8 TON

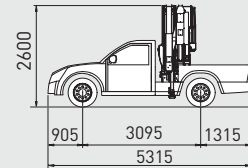
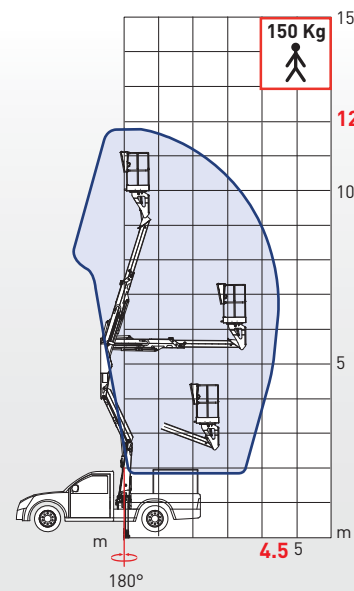

12 m	4.5 m	150 kg	180°	-	A
min. GVW 2.8 Ton					

- KING CAB & DOUBLE CAB VEHICLE
- ARTICULATED TERMINAL FLY BOOM - JIB
- FROM 3.2 TON

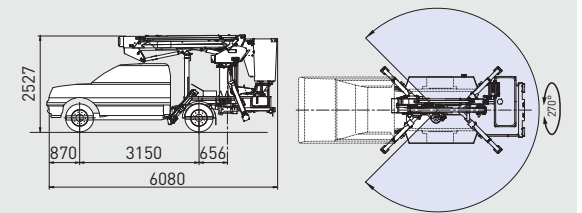
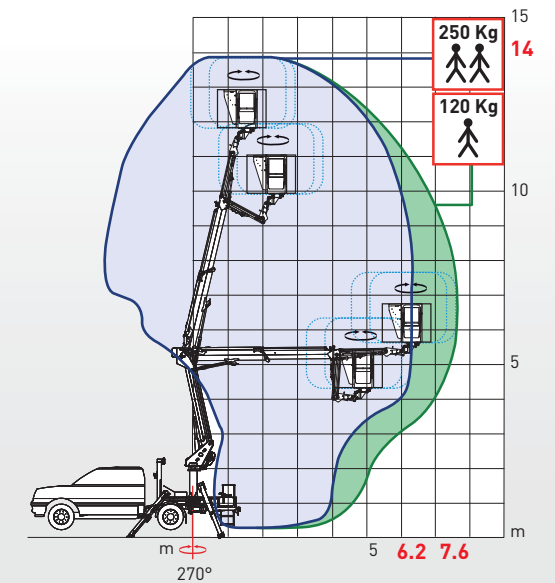

14 m	6.2 (7.6) m	250 (120) kg	270°	90° + 90°	A + A
min. GVW 3.2 Ton					

- FREE SPACE IN THE REAR BODY TO TRANSPORT MATERIALS
- SINGLE CAB VEHICLE
- FROM 2.8 TON

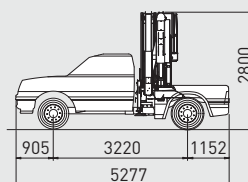
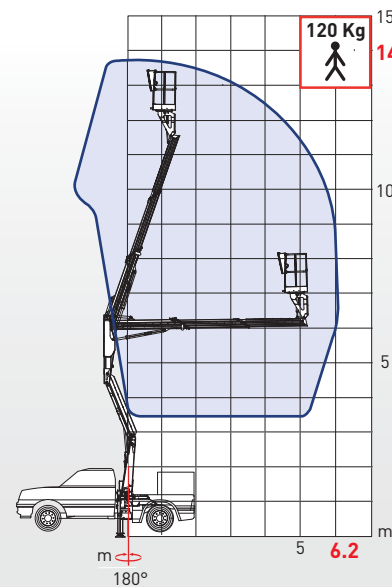

14 m	6.2 m	120 kg	180°	-	HE
min. GVW 2.8 Ton					

- SINGLE CAB VEHICLE
- DOUBLE PANTOGRAPH
- ARTICULATED TERMINAL FLY BOOM - JIB
- FROM 3.2 TON

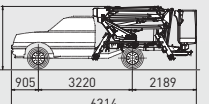
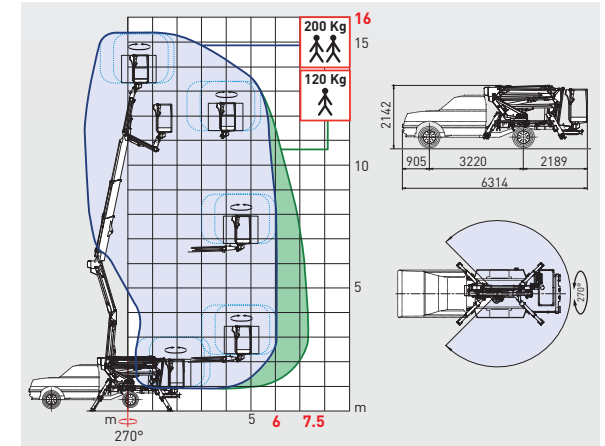
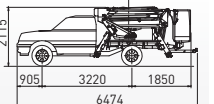
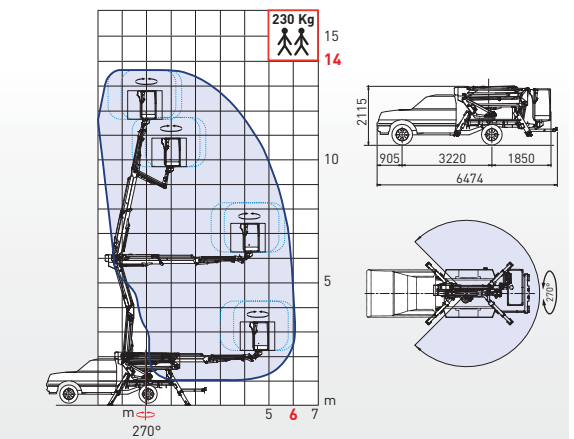

14 m	6 m	230 kg	270°	90° + 90°	A + A
16 m	6 (7.5) m	200 (120) kg	270°	90° + 90°	A + A
min. GVW 3.2 Ton					